

Gate Valve

STAAL 40 AKD/AKDS

Type Series Booklet



Legal information/Copyright

Type Series Booklet STAAL 40 AKD/AKDS

All rights reserved. The contents provided herein must neither be distributed, copied, reproduced, edited or processed for any other purpose, nor otherwise transmitted, published or made available to a third party without the manufacturer's express written consent.

Subject to technical modification without prior notice.

© KSB SE & Co. KGaA, Frankenthal 14/10/2019

Contents

Gate Valves.....	4
Gate Valves to DIN/EN with Bolted Bonnet	4
STAAL 40 AKD/AKDS.....	4
Main applications.....	4
Fluids handled	4
Operating data.....	4
Valve body materials.....	4
Design details	4
Product benefits.....	5
Product information	5
Related documents	5
Purchase order specifications	6
Pressure/temperature ratings.....	6
Materials.....	7
Variants.....	9
Dimensions and weights.....	10
Installation information.....	13

Gate Valves

Gate Valves to DIN/EN with Bolted Bonnet

STAAL 40 AKD/AKDS



Main applications

- Chemical industry
- Boiler feed applications
- Boiler recirculation
- Cooling circuits
- Condensate transport
- Petrochemical industry
- Process engineering
- Heat recovery systems
- Sugar industry
- Mining
- Descaling units
- Fossil-fuelled power stations
- Pulp and paper industry
- Shipbuilding
- Snow-making systems
- Nuclear power stations

Fluids handled

- Water
- Steam
- Other non-aggressive fluids such as gas or oil on request.

Operating data

Operating properties

Characteristic	Value
Nominal pressure	PN 10 - 40
Nominal size	DN 50 - 900
Max. permissible pressure [bar]	40
Min. permissible temperature [°C]	≥ -10
Max. permissible temperature [°C]	≤ +530

Selection as per pressure/temperature ratings (⇒ Page 6)

Valve body materials

DN 50 - 200

Overview of available materials

Material	Material number	Temperature limit
P 250 GH	1.0460	≤ 450 °C

DN 250 - 900

Overview of available materials

Material	Material number	Temperature limit
P 265 GH	1.0425	≤ 450 °C
16 Mo 3	1.5415	≤ 500 °C
13 CrMo 4-5	1.7335	≤ 530 °C

11 CrMo 9-10 on request

Design details

Design

- Body of forged or welded steel construction
- Bolted bonnet
- Non-rotating stem with external screw
- Split wedge
- Standard position indicator ≤ DN 200
- Yoke head suitable for mounting electric actuators (DIN ISO 5210)

Variants

- Stem protecting tube
- Stem protecting tube with position indicator (≥ DN 250)
- Stem protecting tube with position switch (≥ DN 250)
- Position switch(es) mounted on yoke (≤ DN 200)
- Bypass
- Drain branch
- Barrier water connection
- Electric actuators
- Bevel gear and spur gear (recommended from ≥ DN 700)
- Installation kit for actuators and manual gearboxes
- Seat/disc interface made of wear-resistant and corrosion-proof Stellite
- Stem made of 1.4122
- TA-Luft-compliant model (with or without spring loading) for applications to VDI 2440 at temperatures ≤ 250 °C and > 250 °C (400 °C maximum)

- Other flange designs or butt weld end designs
- Inspections to technical codes such as TRD/TRB/AD2000 – German Steam Boiler / Pressure Vessel Regulations – or to customer specification
- ≥ DN 900 on request

Product benefits

- Reliable, tight shut-off and service-friendly design
 - Wedge holder with flexibly mounted split wedge. Precise alignment of wedge discs with body seats; wedge discs are easy to replace.
 - Actuating moments are absorbed by the wedge holder guided in the body. No additional loads on the wedge discs and the seat/disc interface.
 - Easy mounting of actuator on yoke head.
- Additional safety and blow-out protection by standard back seat.
- Long service life and high functional reliability
 - Stop nut as standard. Limited wedge action prevents jamming in closed position and ensures reliable opening of the gate valve even in the event of temperature transients.
 - Of the gland packing due to non-rotating stem with burnished shank.
 - Threaded bush runs in ball bearings for smooth actuation.
 - Hard-faced seat/disc interface made of wear-resistant and corrosion-proof 17 % chrome steel or Stellite.
- Threaded bush free from non-ferrous metals, for versatile application.

Product information

Product information as per Regulation No. 1907/2006 (REACH)

For information as per chemicals Regulation (EC) No. 1907/2006 (REACH), see <http://www.ksb.com/reach>.

Product information as per Directive 2014/34/EU (ATEX)

The valves do not have a potential internal source of ignition and can be used in potentially explosive atmospheres, Group II, category 2 (zones 1+21) and category 3 (zones 2+22) to ATEX 2014/34/EU.

Product information as per Pressure Equipment Directive 2014/68/EU (PED)

The valves satisfy the safety requirements of Annex I of the European Pressure Equipment Directive 2014/68/EU (PED) for fluids in Groups 1 and 2.

Related documents

Information/documents

Document	Reference number
STAAL 40 AKK/AKKS type series booklet (swing check valves)	7365.1
Operating manual	0570.81
Typical tender for STAAL 40 AKD/AKDS	7364.520

7364.1/20-EN

Purchase order specifications

Please specify the following information in all enquiries or purchase orders:

- | | |
|--|--|
| <ol style="list-style-type: none"> 1. Type 2. Nominal pressure 3. Nominal size 4. Operating pressure 5. Differential pressure | <ol style="list-style-type: none"> 6. Operating temperature 7. Material 8. Fluid handled 9. Flow rate 10. Pipe connection 11. Variants 12. Reference number |
|--|--|

Always indicate the original serial number and the year of construction when ordering spare parts.

Pressure/temperature ratings

Permissible operating pressure [bar] (to EN 1092-1)¹⁾

PN	Material	[°C]																
		RT ²⁾	100	150	200	250	300	350	400	450	460	470	480	490	500	510	520	530
10	P 250 GH / P 265 GH	10,0	9,2	8,8	8,3	7,6	6,9	6,4	5,9	3,2	-	-	-	-	-	-	-	-
16		16,0	14,8	14,0	13,3	12,1	11,0	10,2	9,5	5,2	-	-	-	-	-	-	-	-
25		25,0	23,2	22,0	20,8	19,0	17,2	16,0	14,8	8,2	-	-	-	-	-	-	-	-
40		40,0	37,1	35,2	33,3	30,4	27,6	25,7	23,8	13,1	-	-	-	-	-	-	-	-
40	16 Mo 3	40,0	40,0	40,0	40,0	39,0	34,2	32,3	29,9	27,6	25,6	23,6	21,6	19,7	17,7	-	-	-
40	13 CrMo 4-5	40,0	40,0	40,0	40,0	40,0	40,0	38,0	36,0	33,7	32,0	30,4	28,8	27,2	26,0	22,0	17,9	14,8

1) Operating pressures in accordance with DIN 2401 are also permissible.
2) RT: room temperature (-10 °C to +50 °C)

Materials

PN 10 - 40
DN 50 - 200

PN 40
DN 250 - 600

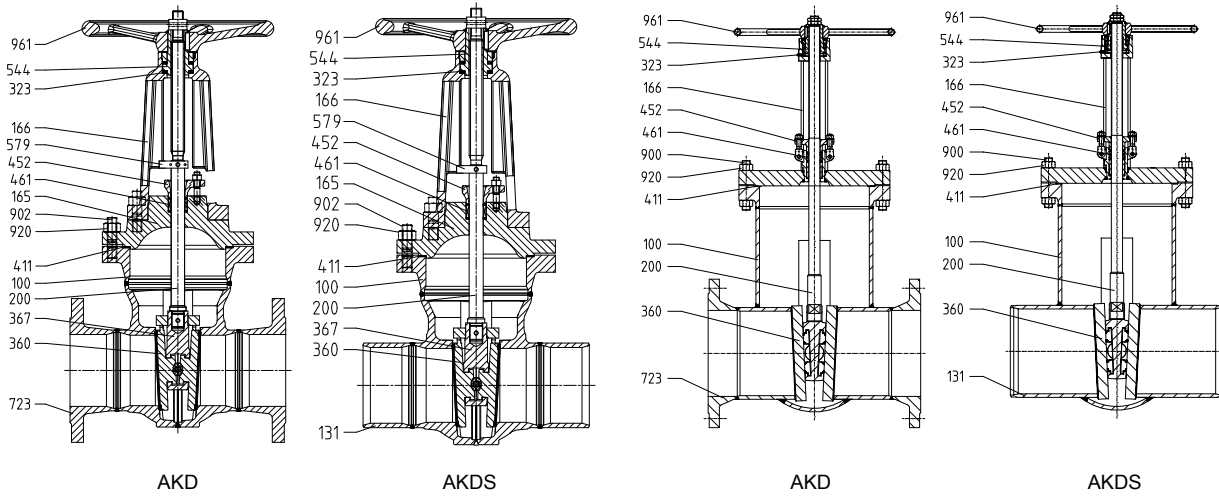

1) PN 40, DN 700 - 800
1) PN 10/16, DN 900

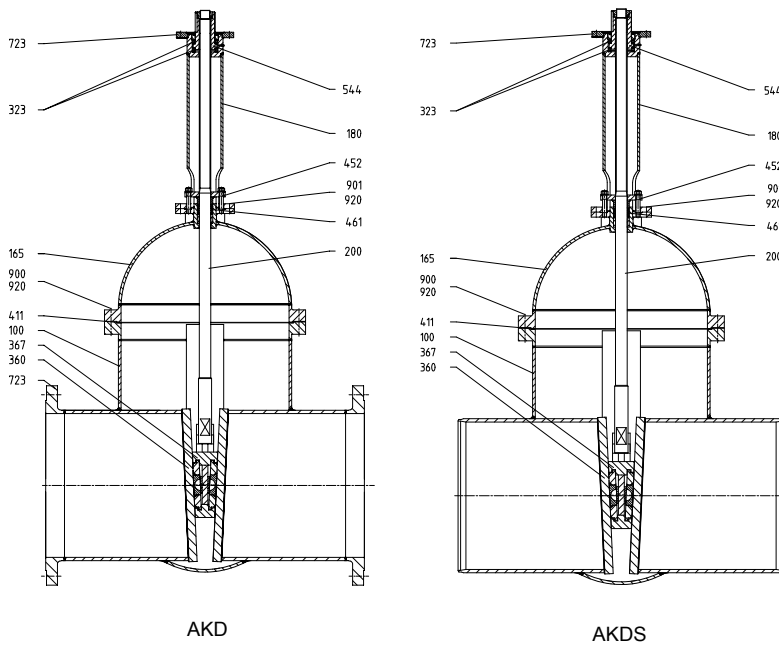

Fig. 1: Sectional drawings; 1) Gearbox recommended

Parts list DN 50 - 200 PN 10 - 40

Part No.	Description	Material	Material number	Note
100	Body	P 250 GH	1.0460	-
		P 265 GH	1.0425	≥ DN 250
131.1	Connection branch	P 235 GH	1.0345	-
		P 265 GH	1.0425	≥ DN 450
165	Bonnet	P 250 GH	1.0460	-
166	Yoke	GP 240 GH+N	1.0619+N	-
		P 265 GH	1.0425	≥ DN 250
200 ³⁾	Stem	X 20 Cr 13+QT800	1.4021+QT800	-

3) Recommended spare parts

Part No.	Description	Material	Material number	Note
323 ³⁾	Thrust bearing	Steel	-	-
360 ³⁾	Wedge discs	GP 240 GH+N	1.0619+N	-
		P 265 GH	1.0425	≥ DN 250
367 ³⁾	Disc/wedge holder	P 250 GH	1.0460	-
		P 265 GH	1.0425	≥ DN 250
Seat/disc interface	Body	X 20 CrMo 17 1	1.4115	17 % chrome steel
	Wedge discs	X 8 CrTi 18	1.4502	
411 ³⁾	Joint ring	CrNi steel/graphite	-	-
452	Gland follower	P 250 GH/P 265 GH	1.0460 / 1.0425	-
461 ³⁾	Gland packing	Pure graphite	-	-
544 ³⁾	Threaded bush	46 S 20+C	1.0727+C	DN 50 - 200, nitrocarburised
		11 SMn 30+C	1.0715+C	≥ DN 250, nitrided
579	Stop	S 235 JR	-	-
723	Flange	P 250 GH	1.0460	-
902	Stud	25 CrMo 4	1.7218	-
920	Hexagon nut	C 35 E	1.1181	-
961	Handwheel	EN-GJL-250	5.1301	DN 50-200
		Steel	-	≥ DN 250

Parts list DN 250 - 800 PN 40 / DN 900 PN 10 - 16

Part No.	Description	Temperature	Material	Material number	Note
100	Body	≤ 450	P 265 GH	1.0425	Body of welded steel construction
		≤ 500	16 Mo 3	1.5415	
		≤ 530	13 CrMo 4-5	1.7334	
723	Flange	≤ 450	P 250 GH / P 265 GH	1.0460 / 1.0425	-
		≤ 500	16 Mo 3	1.5415	-
		≤ 530	13 CrMo 4-5	1.7335	-
131.1	Connection branch	≤ 450	P 265 GH	1.4025	Material can be matched to piping material
		≤ 500	16 Mo 3	1.5415	
		≤ 530	13 CrMo 4-5	1.7335	
360 ³⁾	Wedge discs	≤ 450	P 265 GH	1.4025	-
		≤ 500	16 Mo 3	1.5415	-
		≤ 530	13 CrMo 4-5	1.7335	-
367 ³⁾	Disc/wedge holder	≤ 450	P 265 GH	1.4025	-
		≤ 500	16 Mo 3	1.5415	-
		≤ 530	13 CrMo 4-5	1.7335	-
166	Yoke	≤ 450	P 265 GH	1.4025	-
		≤ 500	16 Mo 3	1.5415	-
		≤ 530	13 CrMo 4-5	1.7335	-
Seat/disc interface	Body	≤ 450	X 20 CrMo 17-1	1.4115	Hard-faced
		≤ 530	Stellite	-	
	Wedge discs	≤ 450	X 8 CrTi 18	1.4502	
		≤ 530	Stellite	-	
200 ³⁾	Stem	≤ 530	X 39 CrMo 17-1	1.4122	-
411 ³⁾	Joint ring	≤ 530	1.4541-Grafit	-	Serrated gasket
452	Gland follower	≤ 530	P 250 GH/P 265 GH	1.0460 / 1.0425	-
461 ³⁾	Gland packing	≤ 530	Graphite	-	Compression-moulded rings (with packing end rings)
544 ³⁾	Threaded bush	≤ 530	Cu Zn 35 Ni 2	2.0540	On thrust bearing
900	Screw	≤ 450	25 CrMo 4	-	-
		≤ 530	21 CrMoV 5-7	1.7709	-
920	Hexagon nut	≤ 450	25 CrMo 4	1.7218	-
		≤ 530	25 CrMo 4	1.7218	-
961	Handwheel	≤ 530	Steel	-	Non-rising

Variants

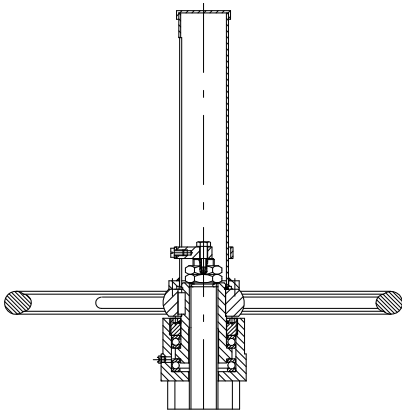

Stem protecting tube with position indicator (DN 250 and above)

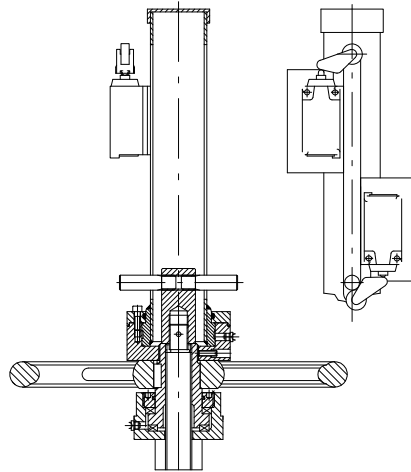

Stem protecting tube with position switch (DN 250 and above)

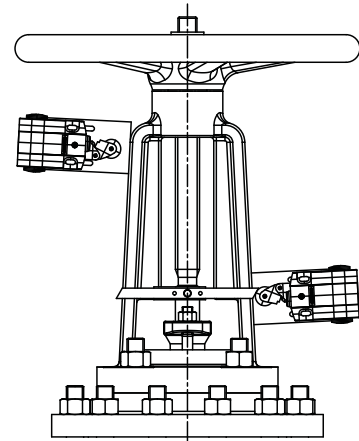

Position switches mounted on yoke (up to DN 200)

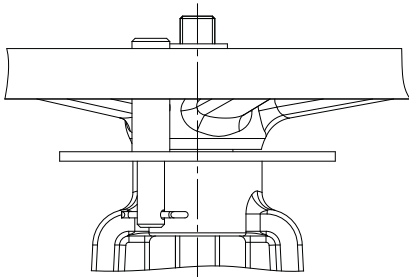

Locking device with split pin

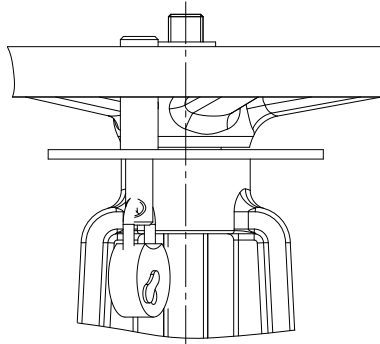

Locking device with padlock

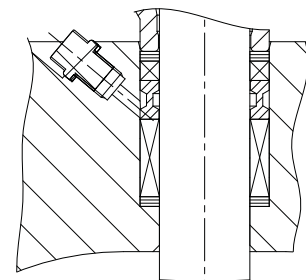

Barrier water connection

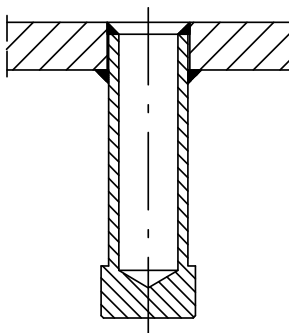

Drain branch

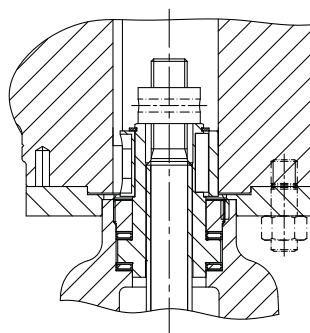

Installation kit for actuators and manual gearboxes

Dimensions and weights

Dimensions and weights of STAAL 40 AKD

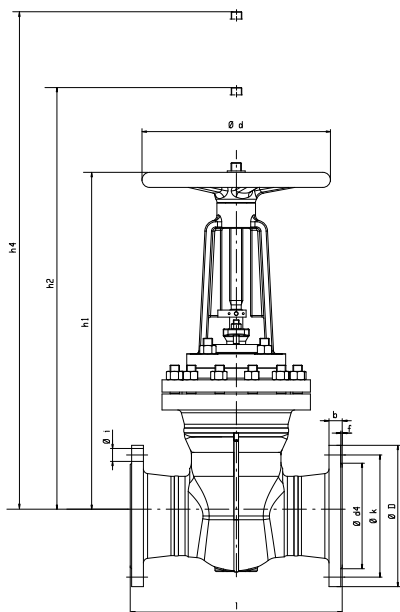

Fig. 2: Sectional drawing

Dimensions and weights

PN	DN	l [mm]	ø D [mm]	ø k [mm]	Number of bolt holes z	Bolt hole dia. i [mm]	ø d ₄ × f [mm]	b [mm]	h ₁ [mm]	h ₂ ⁴⁾ [mm]	h ₄ ⁵⁾ [mm]	ø d [mm]	[kg]
10	50	250	165	125	4	18	102 × 3	18	375	435	515	160	18
	65/50	270	185	145	8	18	122 × 3	18	375	435	515	160	20
	80	280	200	160	8	18	138 × 3	20	490	580	700	200	44
	100	300	220	180	8	18	158 × 3	20	600	710	850	250	66
	125/100	325	250	210	8	18	188 × 3	22	600	710	850	250	77
	150	350	285	240	8	22	212 × 3	22	750	915	1100	400	121
	200	400	340	295	8	22	268 × 3	24	875	1085	1320	400	182
900	1950	1115	1050	28	33	1005 × 5 ⁶⁾		2800	3800	4350	7)	3250	
16	50	250	165	125	4	18	102 × 3	18	375	435	515	160	18
	65/50	270	185	145	8	18	122 × 3	18	375	435	515	160	20
	80	280	200	160	8	18	138 × 3	20	490	580	700	200	44
	100	300	220	180	8	18	158 × 3	20	600	710	850	250	64
	125/100	325	250	210	8	18	188 × 3	22	600	710	850	250	64
	150	350	285	240	8	22	212 × 3	22	750	915	1100	400	121
	200	400	340	295	12	22	268 × 3	24	875	1085	1320	400	181
900	1950	1125	1050	28	39	1000 × 5 ⁶⁾		2800	3800	4350	7)	3350	
25	50	250	165	125	4	18	102 × 3	20	375	435	515	160	18
	65/50	270	185	145	8	18	122 × 3	22	375	435	515	160	24
	80	280	200	160	8	18	138 × 3	24	490	580	700	200	37
	100	300	235	190	8	22	162 × 3	24	600	710	850	250	66
	125/100	325	270	220	8	26	188 × 3	26	600	710	850	250	66
	150	350	300	250	8	26	218 × 3	28	750	915	1100	400	124
	200	400	360	310	12	26	278 × 3	30	875	1085	1320	400	186
40	50	250	165	125	4	18	102 × 3	20	375	435	515	160	23
	65/50	290	185	145	8	18	122 × 3	22	375	435	515	160	23
	80	310	200	160	8	18	138 × 3	24	490	580	700	200	38

4) Open
5) Vertical clearance for removal
6) To be specified by user in accordance with EN 1092-1
7) With bevel gear or spur gear

PN	DN	l	ø D	ø k	Number of bolt holes z	Bolt hole dia. i	ø d ₄ × f	b	h ₁	h ₂ ⁴⁾	h ₄ ⁵⁾	ø d	[kg]
		[mm]	[mm]	[mm]		[mm]	[mm]	[mm]	[mm]	[mm]	[mm]	[mm]	
40	100	350	235	190	8	22	162 × 3	24	600	710	850	250	68
	125/100	400	270	220	8	26	188 × 3	26	600	710	850	250	68
	150	450	300	250	8	26	218 × 3	28	750	915	1100	400	127
	200	550	375	320	12	30	285 × 3	34	875	1085	1320	400	194
	250	650	450	385	12	33	345 × 3	38	1100	1375	1765	560	370
	300	750	515	450	16	33	410 × 4	42	1245	1575	2020	640	525
	350	850	580	510	16	36	465 × 4	46	1360	1720	2220	640	710
	400	950	660	585	16	39	535 × 4	50	1510	1925	2475	720	950
	450	1050	685	610	20	39	560 × 4	57	1830	2345	3020	800	1505
	500	1150	755	670	20	42	615 × 4	57	1830	2345	3020	800	1605
	600	1350	890	795	20	48	735 × 5	72	2170	2790	3590	1000	2710
	700	1550	995	900	24	48	840 × 5	⁶⁾	2465	3200	3590	1000	3400
800	1750	1140	1030	24	56	960 × 5	⁶⁾	2800	3740	4150	1000	4700	

Mating dimensions as per standard

Face-to-face lengths: PN 10-25: EN 558-1/15
PN 40: EN 558-1/26, ISO 5752/T1

Flanges: DIN EN 1092-1, DIN 2501, ISO 2084, BS 4504

Flange facing: Type B

Other flange designs

- E.g. groove (type D), tongue (type C), recess (type F), spigot (type E) to EN 1092-1 at both ends
- Other flange designs on request

Dimensions and weights of STAAL 40 AKDS

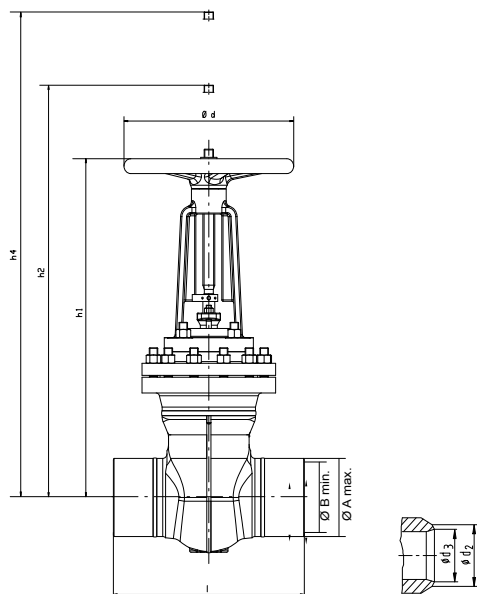

Fig. 3: Sectional drawing

Dimensions and weights

PN	DN	l	Butt weld ends, unmachined		Butt weld ends, machined		Associated pipe dimensions	h ₁	h ₂ ⁸⁾	h ₄ ⁹⁾	ø d	[kg]
			ø A _{max.}	ø B _{min.}	ø d ₂	ø d ₃						
		[mm]	[mm]	[mm]	[mm]	[mm]	[mm]	[mm]	[mm]	[mm]	[mm]	
10/16	50	250	60,3	46,1	60,3	54,5	60,3 × 2,9	375	435	515	160	17
	65/50	270	76,1	44,1	76,1	70,0	76,1 × 2,9	375	435	515	160	20
	80	280	88,9	72,9	88,9	82,0	88,9 × 3,2	490	580	700	200	33
	100	300	114,3	94,3	114,3	106,5	114,3 × 3,6	600	710	850	250	61
	125/100	325	139,7	99,7	139,7	131,0	139,7 × 4,0	600	710	850	250	62
	150	350	168,3	148,3	168,3	158,5	168,3 × 4,5	750	915	1100	400	100
	200	400	219,1	199,1	219,1	205,5	219,1 × 6,3	875	1085	1320	400	173
	900	1950	920,0	880,0	914,0	889,0	914,0 × 10,0	2800	3800	4350	¹⁰⁾	3100
25	50	250	60,3	46,1	60,3	54,5	60,3 × 2,9	375	435	515	160	17
	65/50	270	76,1	44,1	76,1	70,0	76,1 × 2,9	375	435	515	160	20
	80	280	88,9	72,9	88,9	82,0	88,9 × 3,2	490	580	700	200	33
	100	300	114,3	94,3	114,3	106,5	114,3 × 3,6	600	710	850	250	61
	125/100	325	139,7	99,7	139,7	131,0	139,7 × 4,0	600	710	850	250	62
	150	350	168,3	148,3	168,3	158,5	168,3 × 4,5	750	915	1100	400	100
	200	400	219,1	199,1	219,1	205,5	219,1 × 6,3	875	1085	1320	400	173
40	50	250	60,3	46,1	60,3	54,5	60,3 × 2,9	375	435	515	160	20
	65/50	290	76,1	44,1	76,1	70,0	76,1 × 2,9	375	435	515	160	20
	80	310	88,9	72,9	88,9	82,0	88,9 × 3,2	490	580	700	200	34
	100	350	114,3	94,3	114,3	106,5	114,3 × 3,6	600	710	850	250	61
	125/100	400	139,7	99,7	139,7	131,0	139,7 × 4,0	600	710	850	250	62
	150	450	168,3	148,3	168,3	158,5	168,3 × 4,5	750	915	1100	400	102
	200	550	219,1	199,1	219,1	205,5	219,1 × 6,3	875	1085	1320	400	176
	250	650	273,0	244,6	273,0	260,0	273,0 × 6,3	1100	1375	1765	560	332
	300	750	323,9	302,0	323,9	309,0	323,9 × 7,1	1245	1575	2020	640	465
	350	850	355,6	332,0	355,6	337,5	355,6 × 8,8	1360	1720	2220	640	610
	400	950	406,4	380,0	406,4	388,0	406,4 × 8,8	1510	1925	2475	720	780
	450	1050	460,0	432,0	457,0	435,0	457,0 × 10,0	1830	2345	3020	800	1305
	500	1150	508,0	482,0	508,0	483,5	508,0 × 11,0	1830	2345	3020	800	1440
	600	1350	615,0	582,0	610,0	582,0	610,0 × 12,5	2170	2790	3590	1000	2437

8) Open
9) Vertical clearance for removal
10) With bevel gear or spur gear

PN	DN	l	Butt weld ends, unmachined		Butt weld ends, machined		Associated pipe dimensions	h ₁	h ₂ ⁸⁾	h ₄ ⁹⁾	ø d	[kg]
			ø A _{max.}	ø B _{min.}	ø d ₂	ø d ₃						
			[mm]	[mm]	[mm]	[mm]						
40	700	1550	720,0	670,0	711,0	678,0	711,0 x 15,0	2465	3200	3590	1000	2750
	800	1750	820,0	760,0	813,0	760,0	813,0 x 18,0	2800	3740	4150	1000	4000

Mating dimensions as per standard

Face-to-face lengths: PN 10 - 25: EN 12982/15
PN 40: EN 12982/26

Butt weld ends: see table

Weld groove form: DIN EN 12627, ASME B16.25

Different designs of butt weld ends and weld groove forms are possible, but only within the dimensions A_{max.} and B_{min.}.

Butt weld ends to DIN 3239 and/or ISO 9692-1 are possible.

Installation information

The gate valves are designed for a max. differential pressure equal to the permissible operating pressure.

If a bypass line is required or requested for other reasons, a NORI 40 ZXS globe valve as per type series booklet 7621.1 is used as a bypass valve. The nominal size of the globe valve depends on the gate valve nominal size (see table).

Nominal size of bypass valve

Nominal size of gate valve	Nominal size of bypass valve
DN 150 - 200	DN 15
DN 250 - 350	DN 25
DN 400 - 600	DN 40
DN 700 - 900	DN 50



KSB SE & Co. KGaA
Bahnhofplatz 1 • 91257 Pegnitz (Germany)
Tel. +49 9241 71-0
www.ksb.com